

**DIRECTION FOR USE AND MAINTENANCE**

Micerium S.p.A. thanks you to have bought a product of its own brand and asks you to read this handbook. Inside you'll find all the necessary information for a correct use of the acquired unit, the user is consequently requested to follow with attention the included instructions and to read the entire handbook. In addition it should be kept in a suitable place to maintain it unchanged. The substance of this handbook can be modified without warning, or further obligations, with the purpose of including alterations and improvements to the already delivered units. It's forbidden to copy or to translate any parts of this handbook without written advice by the owner. Don't use the unit for any other purposes than the ones projected. The eligibility is published by the affixing of the data plate representing the CE mark on the unit and by the herewith enclosed declaration of conformity.

**READ AND KEEP THESE INSTRUCTIONS**

## CE DECLARATION OF CONFORMITY

WE

**MICERIUM SPA**  
**VIA G. MARCONI, 83**  
**16036 AVEGNO (GE) ITALIA**  
**Tel.: +39-0185-7887870 fax: +39-0185-7887970**

DECLARE UNDER OUR EXCLUSIVE RESPONSIBILITY THAT THE PRODUCT:

**RUTEX ROUTER**  
**MODEL PX801-CE**

WHICH THIS DECLARATION IS REFERRED TO, IS IN COMPLIANCE WITH WHAT  
IS ESTABLISHED BY THE DIRECTIVES:

**2006/42/CE (MD)**  
**2014/30/UE (Electromagnetic compatibility EMC)**  
**2014/35/UE (LVD)**  
**2011/65/EU (2016/1029/EU) - RoHS**  
**2012/19/EU - RAEE**  
**AND FURTHER MODIFICATIONS**

Avegno (GE), **October 2017**

(Dr. Eugenio Miceli)



## SYMBOLS ON EQUIPMENT AND/OR ON BOX - DISPOSAL OF THE UNIT

Caution. Specific warnings and precautions associated with this device



See instructions for use



Product reference



Serial number followed by device model



This product is covered by the European Directive 2012/19/UE, for the reduction of the use of hazardous substances in electrical and electronic equipment, and disposal of waste. The symbol of bin crossed reported on your equipment or its packaging indicates that the product at the end of its useful life must be disposed separately from other waste. A separate collection of this equipment arrived at the end of its life is organized and managed by the manufacturer. If you want to get rid of this equipment, please contact the manufacturer and follow the system that he has chosen to allow separate collection of the apparatus arrived at the end of its life. A proper separate collection for the next launch of the disused equipment to recycling, treatment and environmentally compatible disposal helps to avoid possible negative effects on the environment and on health and promotes reuse and / or recycling of materials composing the equipment. The illegal disposal of the product by the holder includes the application of administrative sanctions provided for by law.



## SAFETY DIRECTIONS

Read and keep these instructions

Look out!: with the use of electric tools and to avoid contacts with electric power, injuries and danger of fire, the following safety directions must always be observed.

Read and observe these indications before using the unit and keep with care these directions.

1. **Keep your working place in order** - Disorder on the working place may cause accidents.
2. **Environmental conditions** - Don't expose electric tools to the rain. Don't use electric tools in wet or soaked places. Take care of good light conditions. Don't use electric tools near inflammable liquids or gas.
3. **Avoid electrification** - Avoid contacts with earthing objects, for ex.tubes, radiators, refrigerators.
4. **Keep children away** - Don't let third persons touch the unit or the cord, keep them far from the working place.
5. **Put your tool in a safe place** - Put your unit in a dry and safe place in order to not be accessible by children.
6. **Don't overload your tool** - You'll work better and safer using the rating plate's power.
7. **Choice of the unit** - Don't use low power tools or accessory that must be used with high power. Don't use tools for work and purposes to which they aren't designed.
8. **Work attire** - During working, always dress properly, avoiding the use of loose-fitting dresses or too large sleeves.
9. **Use safety glasses** - Always use protective glasses. If you should work or something that produces dust, use a mask.
10. **Pay attention to the cord** - Don't lift the tool by the cord and don't use it to pull off the plug from the tap. Avoid contacts between the cord and high temperatures, oils, edges.
11. **Avoid unsafe positions** - Be sure to stay in a safe position, in order to maintain a good balance.
12. **Take care of your tools** - In order to work in a safe way, sharper and clean your tools, follow the assistance prescriptions and the directions about the change of using tools.  
Often control the cord and, in case of damages, have qualified people change it. Control regularly the extension cords and change them if they are damaged; the side handgrips must be dry and without oil or fat.
13. **Changing of working tools** - Before making repairs and changing of tools, (f. e. saw-blades, points and in any case tools), always pull off the plug from the power tap.
14. **Don't leave service keys on the unit** - Before using the tool be sure that service keys are taken away.
15. **Avoid unworked startings** - Before Your put the plug in the power tap be always sure that the switch is off.
16. **Don't use the unit in open places** - The unit must be used in well lighted and only indoors
17. **Always be careful working** - While working, don't be distracted. A lack of attention can cause accidents. In presence of other people in the working place, we recommend to maintain a suitable distance from the operator and the unit, in order to avoid unwanted and unintentional contact with machine parts in motion or residues of cuts.
18. **Always control that the tool isn't damaged** - Before using the unit, check with attention its efficiency and the perfect working of the safety devices and if necessary of damaged parts.  
Control the efficiency of the movable parts, that they aren't blocked, that there aren't broken parts, that the others are assembled in a right way and that all the conditions that could influence the correct efficiency of the unit are optimal. Safety devices or damaged parts must be repaired or changed by a Authorised Centre of Assistance if different indications aren't given.
19. **Watch out!** - For your safety use only tools or accessories indicated in the direction for use or offered in proper catalogues. The use of different accessories or using tools, or anyway not indicated in the direction for use or in the catalogue, may cause accidents.
20. **Have qualified people change the tools** - This ELECTRIC unit is in conformity with the safety directions in force. The repair of electric tools must be done only by Authorised centres of assistance.

## CONTENTS

1.0	TECHNICAL FEATURES
2.0	DEVICES OF CONTROL
3.0	GENERAL INDICATIONS ABOUT THE UNIT
	3.1 Connection of the exhauster
4.0	INSTALLATION OF THE UNIT
	4.1 Installation
	4.2 ELECTRIC connection
5.0	MOVEMENT
6.0	GENERAL DIRECTIONS FOR USE
	6.1 Indication about the use of the unit
	6.2 Split Cast
7.0	PERIODICAL MAINTENANCE BY THE OPERATOR
	7.1 Mains supply cord
	7.2 Lubrification
	7.3 Changing of the bur
8.0	OBSTACLES - HELPS
9.0	ACCESSORIES
10.0	MANUFACTURER LIMITED GUARANTEE
11.0	ELECTRICAL SCHEME
12.0	PARTS LIST

## 1.0 TECHNICAL FEATURES

Voltage:	220 V. 50 Hz
Weight:	10 kg.
Base:	300x210 mm.
Height:	300 mm.
Tool connector:	6 mm.
Motor power:	1/2 HP

## 2.0 DEVICES OF CONTROL

### 1. STARTING SWITCH

It's the switch which gives tension to the unit .

### 2. EMBEDDING PLUG

It is the member of connection of the unit with the network system.

### 3. FUSEHOLDER

It contains the fuse that protects the engine.

### 4. EMERGENCY STOP PUSH-BUTTON

This mushroom-head push-button has the function of emergency stop. It is set in action when it happens particular dangerous conditions that induce the operator to push it with a quick and instinctive action.

### 5. SWITCH ON LIGHT

It indicates that the engine is running.

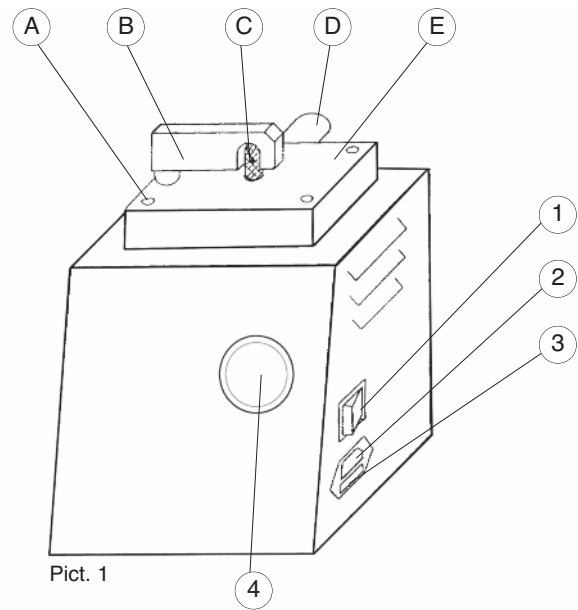

Pict. 1

## 3.0 GENERAL INDICATION ABOUT THE UNIT

This router is especially created for burr and finish off the manufactured articles created in the dental technician lab. It can work, besides the plaster, various kinds of materials, such as acrylic, investment, plexiglass, ABS, etc. It's formed by a painted plate carter to which it's fixed the engine that holds the bur (PART.C of picture 1) and the following particulars:

### - WORKING PLANE (PART. E of picture 1)

Built of inox steel it acts as supporting plane for the working model, and simultaneously as conveyor of the dusts produced during the work. These dusts are then eliminated by the exhauster unit through the posterior connection (PART. D of picture 1).

### - ELECTRIC SYSTEM

It is formed by various parts such as the push-buttons, the relay and the signal light.

The following devices were been adopted in order to adjust the safety of the unit.

### - PROTECTION OF THE BUR

This mobile protection (PART. B of Pict. 1) covering almost all the bur (PART. C. Pict. 1) avoids the casual contact with all the sides except the frontal one. The frontal side must be kept free to allow the protection (PART B of picture 1) to translate back during the work and so to set the sharp part of the model free (PART.C of picture 1).

At the end of this operation the return spring leads the protection in its primitive position (PART.B of picture 1).

### - EMERGENCY STOP PUSH-BUTTON

This push-button (PART. 4 of picture 1) as it's indicated above, has the very important function of emergency stop. Thanks also to its particular shape and position it is extremely practical to been set in action during dangerous moments caused by wrong actions of the operator.

- Connect always to the router connection (PART. D of picture 1) an exhauster of a quite good power that could take away all the deposits and dusts produced during the work.

- Keep always efficient the exhauster system cleaning often the filter and the connecting pipes.

- To protect oneself from an incidental projection of parts or particles of material THE OPERATOR MUST WEAR PROTECTIVE GLASSES AND A DUST MASK.

The use of bearing on the shaft besides guaranteeing a greater duration, brakes the rotation of the tool stopping it in few seconds with the operation of the proper control.

## 3.1 CONNECTION OF THE EXHAUSTER

This operation must be done by qualified personnel.

Important thing: before connecting the exhauster with the unit, be sure that it hasn't a capacity lower than 20 lt/sec

In order to make the connection, follow these indications:

1. Pull off the plug from the power tap of the unit.

2. Connect, through a flexible tube, the exhauster to the unit, plugging it in its proper tube (PART D of pict. 1). The tube must have an inner diameter longer than 20 mm. in order to guarantee the passage of air at least equal to 3 cm, and a length (according to your necessity) so short in order to reduce the loss of the load. In addition it mustn't have excessive crushing or folding.

At the end of the connection prove the functionality of the exhauster system.

## 4.0 INSTALLATION OF THE UNIT

### 4.1 INSTALLATION

- Remove the unit from the package by at the opening side taking care of not to collide against the disk.
- Check that all the parts of the unit are whole. If this should not be the case, immediately contact the retailer.
- Lay the unit on a fixed plane in a well lighted and dry place and, free with space of at its sides, at least 30 cm.
- Now the unit is assembled, ready to work.
- Connect the unit to the exhauster if such should be lacking (model PX901 - par. 3.1)
- Don't throw the package away, but conserve it for next movements.

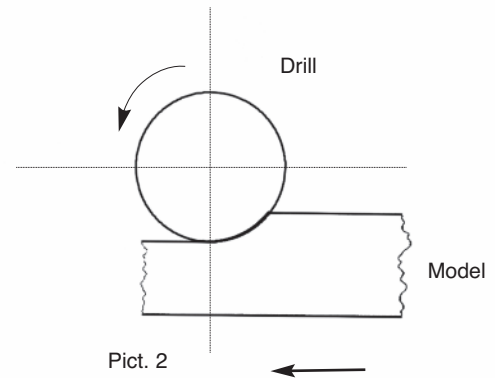

### 4.2 ELECTRIC CONNECTION

Before connecting the unit be sure that the tension of service indicated on the data plate agrees with the one of the system and that it is endowed with earth wire.

- Connect the plug of the ELECTRIC flying cord coming from the unit to the proper tap . Make this operation when the general switch is off. The main supply of the unit must be done according with the instructions of micerium spa that, however, isn't responsible the connection fax.

The endowed mains supply cord is of the model H 05 with a section consistent with the highest absorbed power (indicated in the technical features).

The supplied cord has a length of 2 m. In case of using extensions, be sure that:

- The collocation of the cord doesn't cause damages;
- The point of connection to the ELECTRIC power font guarantees the presence of all the necessary protections for the directions in force.

## 5.0 MOVEMENT

- Conserve the package of the unit that will be useful if you have to move it to a different working place .

In this case, follow the operations indicated below. We suggest you to dismantle the disk in order to avoid it being accidentally damaged casual damage.

- A. Switch off the unit, disconnect the ELECTRIC plug and later pull it out of the unit.
- B. Replace the accessories with the supplied keys in the proper box, and put the latter in the package.
- C. Put the unit in its box in its proper place.
- D. Put in the direction for use and maintenance, than finish the package with soft and impact strong material, than close the box.

## 6.0 GENERAL DIRECTIONS FOR USE

### 6.1 INDICATION ABOUT THE USE OF THE UNIT

The operator must keep himself in front of the unit to work without interferences on the controls.

Concerning the use of the unit, follow these operations chronologically:

1. Switch on the exhauster system.
2. Switch on the unit using the push-button (PART 1 of picture 1), simultaneously to the starting of the engine also the light will be switch on.
3. Prove always that the bur (PART. C of picture 1) swung perfectly on its Centre.
4. THE OPERATOR MUST WEAR GLOVES, PROTECTIVE GLASSES AND A DUST MASK.
5. Lay the model on the working plane (PART E of picture 1) and holding it firmly with both the hands push it delicately in contact with the mobile protection (PART B of picture 1) that will withdraw allowing the unit (PART C of picture 1) to start working.
6. During the work we suggest to use a feed so-called in opposition, where the model moves in the opposite direction of the rotation of the bur (see picture 2).

Don't make an excessive pressure between the model and the bur, that could involve excessive vibrations or the unexpected break of the model.

7. At the end of the work push the stop push-button (PART. 1 of picture 1) that will switch off the unit.

NEVER FORSAKE THE WORKING PLACE LEAVING UNGUARDED THE ROUTER ON.

### LOOK OUT

During the work don't wear loose-fitting dresses and jewels. They could be attracted by the moving bur. If you have long hair, use the hair-net.

## 6.2 SPLITCAST

With this router it's possible to make the splitcast on the plaster model, it's enough to assemble on the working plane (PART 4 of picture 3) the proper plate (PART 3 of picture 3) that is enclosed with the unit.

This simple operation must be made when the unit is disconnected from the mains supply network. To assemble the plate (PART 3 of picture 3) it's necessary to swing the mobile protection (PART 1 of picture 3) as far as the posterior stop point (see picture 3), then lay the plate (PART 3 of picture 3) on the working plane (PART 4 of picture 4) being careful that the two little pins were inserted in the proper holes. Then leave free the mobile protection (PART 3 of picture 1) that owing to the plate (PART 3 of picture 3) will not return in its original position. If the operation was been executed correctly, the bur (PART 2 of picture 3) will stick out from the new working plane only with the spherical part with few millimetres.

To execute the work go on as described at the paragraph 6.1.

To adjust the height of the bur see the indication of paragraph 7.3.

## 7.0 PERIODICAL MAINTENANCE BY THE OPERATOR.

All the maintenance operations must be made when the unit is switch off, disconnected from the feeding.

### 7.1 MAINS SUPPLY CORD

Test periodically the mains supply cord conditions. If it will appear damaged, make qualified people change it.

### 7.2 LUBRIFICATION

The bearing of the engine are waterproof, so it isn't necessary any operation of lubrication. Instead it a good custom to oil and grease the shank of the bur when there is the occasion to remove or change it.

### 7.3 CHANGING OF THE BUR

The bur must be changed when its conditions don't allow to use it in safety conditions. Change it without delay if it appears splintered or if doesn't swing perfectly in its Centre or if it is worn.

The wear of this part is verifiable valuing the effort that the operator use to work.

**LOOK OUT:** before starting the change of the bur be sure that the plug of the unit is disconnected from the tap.

Unscrew the socket head screw (PART A of picture 1) that fixed the working plane (PART E of picture 1) then with the help of the enclosed keys (PART 4 of picture 4) unloose the screw (PART 3 of picture 3) that locks the bur (PART. 1 of picture 4) above the shaft of the engine (PART 2 of picture 4). Make a tractive force upward that will be enough to remove the worn bur (PART 1 of picture 4). Then assemble the new bur and make the above-mentioned operations in the opposite direction.

**LOOK OUT:**

Before starting a new work test that the tool swung with its axis in its Centre.

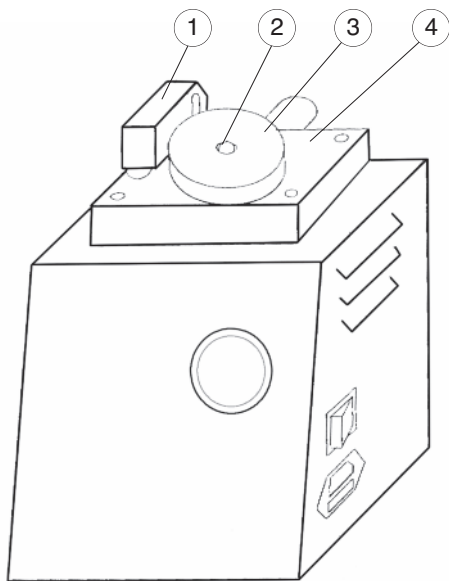

Pict. 3

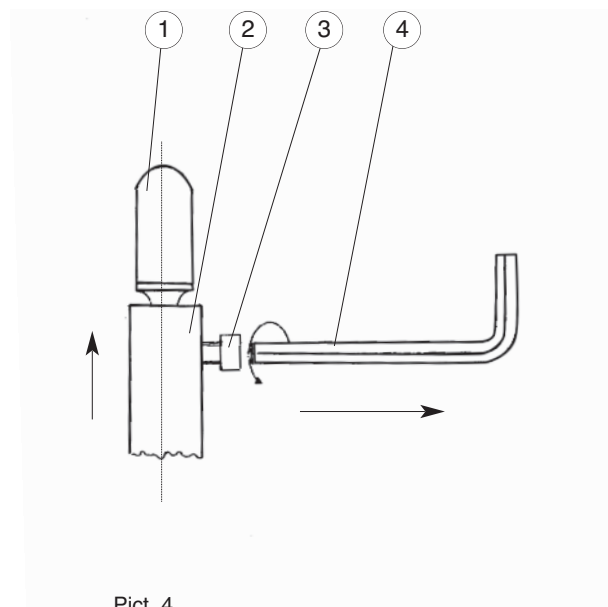

Pict. 4



## 8.0 TROUBLE SHOOTING GUIDE

All this operations must be done when the unit is disconnected .Don' t make operations of maintenance ,regulations or repairs that aren' t indicated in this handbook for use and maintenance . In case of necessity contact our technical assistance.

<b>TROUBLES</b>	<b>CAUSES</b>	<b>SUGGESTIONS</b>
The unit doesn' t work	<ul style="list-style-type: none"><li>- The ELECTRIC power doesn't arrive to the unit</li></ul>	<ul style="list-style-type: none"><li>- Be sure that the cord of connection between the unit and the ELECTRIC system is correctly connected in the respective taps.</li><li>- Control the respective fuse (for this operation turn to qualified personal).</li></ul>
The exhauster, even if it works, doesn' t suck in the dusts made during the cutting	<ul style="list-style-type: none"><li>- The filter is obstructed.</li><li>- The tube that connects the exhauster with the router is obstructed or bent or squashed</li></ul>	<ul style="list-style-type: none"><li>- Disassemble the filter and clean it.</li><li>- Prove this situation and operate</li></ul>
The plaster of the model has a tendency to clog with the bur	<ul style="list-style-type: none"><li>- The model could be too wet</li></ul>	<ul style="list-style-type: none"><li>- Control the drying process of the model</li></ul>
During the working the bur has a tendency to vibrate or to break the model or anyway doesn't work correctly.	<ul style="list-style-type: none"><li>- The bur doesn't swung on its axis</li><li>- The bur is worn</li><li>- The locking of the model with the hands is precarious</li></ul>	<ul style="list-style-type: none"><li>- Verify the clamping of the locking screw</li><li>- Control that the bur wasn't bent because of impacts</li><li>- Control that was correctly assembled</li><li>- Change the bur</li><li>- Lock the model with greater strength and push it on the working plane</li></ul>
The mobile protection of the bur doesn't come back in position	<ul style="list-style-type: none"><li>- The returning spring is released or broken</li></ul>	<ul style="list-style-type: none"><li>- Disassemble the working plane and control the spring (Turn to qualified people)</li></ul>
The mobile protection of the bur although come back, it doesn't stop in the right position	<ul style="list-style-type: none"><li>- The position locking system is loose</li></ul>	<ul style="list-style-type: none"><li>- Disassemble the working plan and adjust it</li></ul>

If the imperfection isn't resolved, although the made checks, we advise you to ask the retailer or the maker.  
For all the damages connected with: transmission, engine or ELECTRIC parts you must ask the maker.

## 9.0 ACCESSORIES

Enclosed accessories

- ELECTRIC cord with a tap EU 60320-C13 and a plug Schuko CEE 7 - VII
- Setscrew wrench of mm. 4
- Setscrew wrench of mm. 3
- Fuse 3,15A
- Plate for splitcast

Accessories disposable on request

- Burs of various shapes: spherical, conical, conical / reverse.

## 10.0 MANUFACTURER LIMITED GUARANTEE

The guarantee is limited micerium spa guarantee that the routex PX801 operated by ELECTRIC engine is free from imperfections of material and processing for a year from the purchasing date.

The guarantee is valid only if the product was bought from micerium spa or Authorised retailers.

This guarantee isn't valid if the product was used in an illicit way, if was altered, changed or repaired by unauthorised personal by Micerium SpA or by unauthorised services' agents. In the case that the product shows, in one year from the purchasing, imperfections of material or processing it must be sent to Micerium SpA or to an Authorised by Micerium SpA service's centre, paying the travelling expenses, enclosing name, address, the purchasing date's proof and a short declaration of the noticed imperfection.

Micerium SpA, as it likes, will make the repair or the change of the imperfect product without any expense by the purchaser.

Possible repairs or changes are guarantee in the above described way for the rest of the original guarantee time. The guarantee is limited to the repair and change of the imperfect product. (There are no other implicit or explicit guarantees and in addition Micerium SpA will be not responsible of casual or special damages or of other damages, costs or expenses except the ones of repair or change as above described).

## 11.0 ELECTRICAL SCHEME

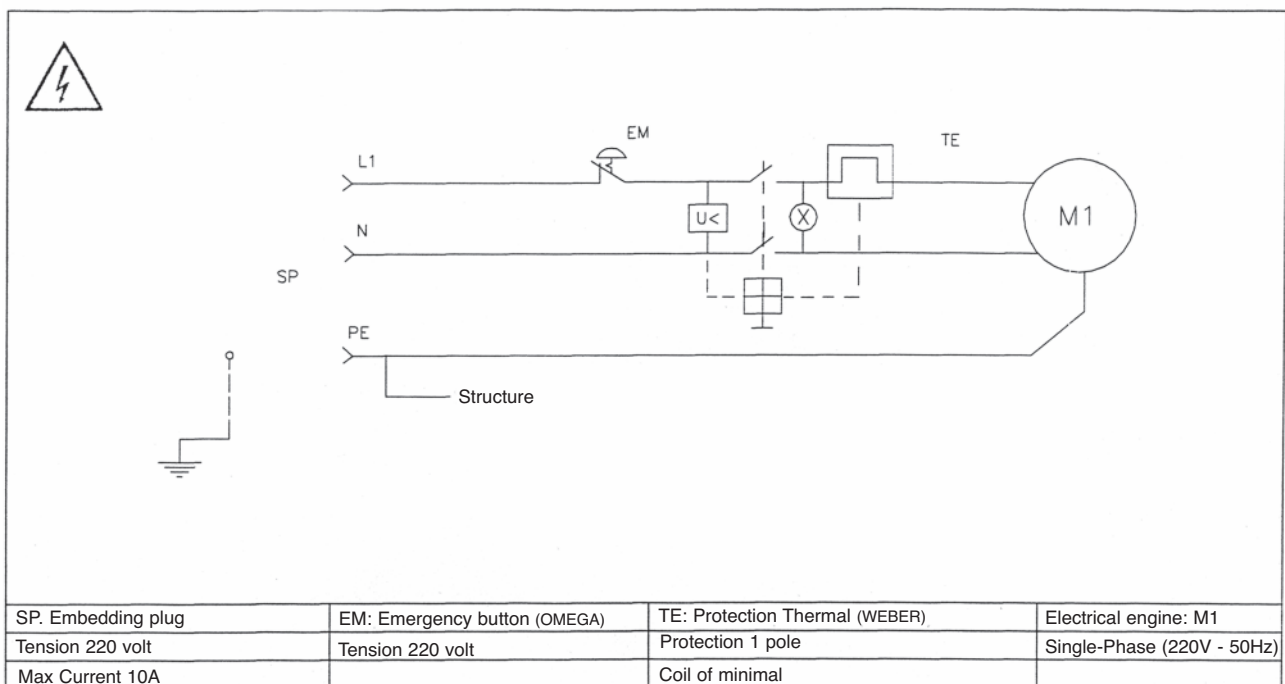

## 12.0 PARTS LIST

PICT.	DESCRIPTION	REF.	PICT.	DESCRIPTION	REF.
1	Screw stud	08101	20	Engine locking screw	08120
2	Nut M6	09098	21	Threaded rivet	08121
3	Plate	08103	22	Working plane locking screw	08122
4	Nut M6	09098	23	Engine	08123
5	Washer	08105	24	Isolating cap	08124
6	Nut M10	08106	25	Emergency push-button	08125
7	Threaded bushing	08107	26	Bolt M3	08126
8	Socket head screw m6x16	08108	27	Self-tapping screw 3,9x10	08127
9	Mobile protection of the bur	08109	28	Socket head screw M5x10	08128
10	Working plane	08110	29	Spring hook	08129
11	Rubber profile	08111	30	Tractive spring	08130
12	Housing	08112	31	Raising working base	08131
13	Switch light	08113	32	Mains supply cord	09093
14	Embedding plug	08114	33	Reduction exhauster connection	08133
15	Self-tapping screw 3.9x10	08115	34	Setscrew wrench 4 mm.	08134
16	Rubber feet	09028	35	Setscrew wrench 3 mm.	08135
17	Housing cover	08117	36	Cone bur (optional)	PX807CE
18	Cylindrical Bur	PX805CE	37	Ball bur (optional)	PX808CE
19	Socket head screw M5x10	08119	38	Inverted cone bur (optional)	PX809CE

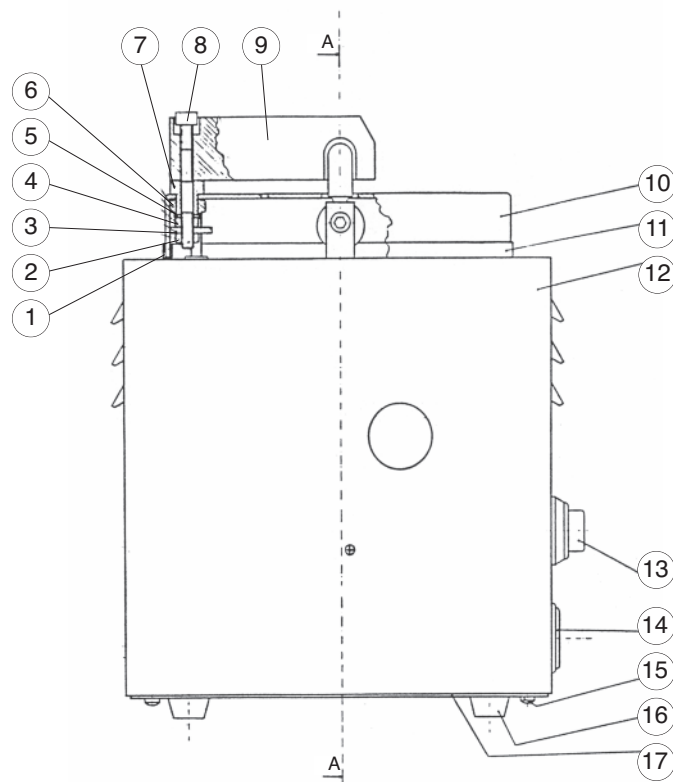

SECT. A-A

